

 aura

# cebilon pro

*USER MANUAL*



Member, Water Quality Association



## *Dear Customer,*

Thank you for choosing our product. We want Cebilon Reverse Osmosis System, manufactured in modern facilities with high quality standards to provide you with the best efficiency. Therefore, please read the entire user manual carefully and keep it as a reference.

Our manual contains information about the technical and hardware features of three different models. The appliance you have purchased may be different from other models in terms of its specifications. During use, please refer to the information on the model you have purchased to avoid problems arising from differences between the models.

# Table of CONTENTS

REVERSE OSMOSIS PROCESS	4
REVERSE OSMOSIS WATER TREATMENT SYSTEMS	5
PART AND FUNCTIONS	6
<i>FUNCTIONS OF THE PARTS</i>	7
<i>FIELDS OF USE</i>	8
<i>OPERATING PRINCIPLE</i>	9
INSTALLATION	10
<i>INSTALLATION SCHEME</i>	11
<i>WATER CONNECTION</i>	11
<i>INSTALLING THE FAUCET</i>	11
<i>WASTE WATER CONNECTION</i>	12
<i>PRE-TEST</i>	12
<i>POINTS FOR ATTENTION</i>	12
MAINTENANCE	13
FILTER REPLACEMENT	13
PERFORMANCE DATA SHEET	13
RECOMMENDED FILTER REPLACEMENT PERIODS	14
INFORMATION ABOUT ARSENIC	15
PART LIST	16
TROUBLESHOOTING	17
DIGITAL DISPLAY FUNCTIONS	18-19
MAINTENANCE CARD	20-21
INSTALLATION CONTROL CARD	22

cebilon  
pro

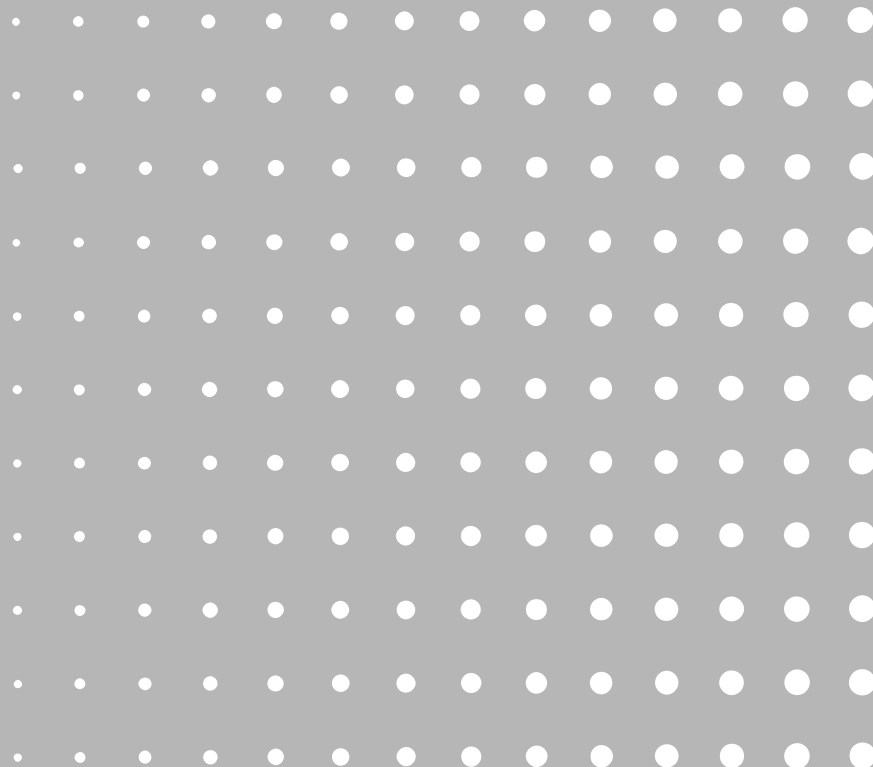
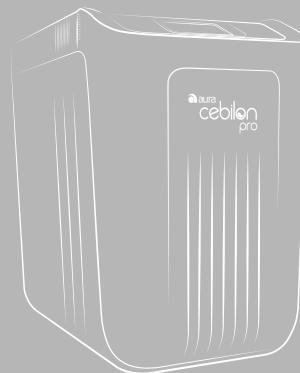

# Osmosis, osmotic pressure, reverse osmosis (ro) process

Osmosis is based on a semi-permeable membrane and a solution; the semi-permeable membrane consisting of a thin membrane or a thin film allows some molecules or ions to pass and does not allow some molecules or ions to pass. Examples of a membrane include cell membranes and egg membrane.

The solution is a homogeneous blend of more than one substance. I.e. it is the distribution of a substance in another substance. The solution is a homogeneous blend of more than one substance. I.e. it is the distribution of a substance in another substance homogeneously with small particles invisible to the eye. This distribution is called dissolution and the mixture obtained is called solution. Generally the substance with less amount in the mixture is called the solute and the substance with more amount is called the solvent. The best solvent among the many found in nature is water. Water dissolves many solid, liquid and gaseous substances. Salt water (sea water) and sugar water (tea) are well-known solutions. homogeneously with small particles invisible to the eye. This distribution is called dissolution and the mixture obtained is called solution. Generally the substance with less amount in the mixture is called the solute and the substance with more amount is called the solvent. The best solvent among the many found in nature is water. Water dissolves many solid, liquid and gaseous substances. Salt water (sea water) and sugar water (tea) are well-known solutions.

Many solids exist as dissolved in waters found in nature. In other words, the water we use is a solution. The water molecules in this solution continuously on the move. As the amount of soluble solids increases, the solid ions occupy the place of the water molecules. In a water with high concentration i.e. with more solid ratio, the number of water molecules is less than the water with same volume but lower concentration, as a result, since the number of moving molecules is less, the thermal internal energy will be less as well. I.e., the energy of the solution with low concentration is higher.

When a semi-permeable membrane is placed between waters with same volume but different concentrations, while the water molecules pass through the pores, the solid particles with a large size cannot pass. Since there are more water molecules in the water with low concentration and as a result more internal energy, more water molecules pass across the other side. The pass rate depends on the concentration ratio, temperature and

pressure. The pass continues until the concentration ratios in both sides are stabilized.

The water level in the high concentration side increases. This pressure arising from the potential energy of this rising water column is stabilized by the Osmotic Pressure. So, the excess of internal energy in the low concentration side is stabilized by the potential energy in the excess of water column in the high concentration side.

If a pressure equal to the pressure that will be built up with the excess in the water column is initially applied to the high concentration side, Osmosis does not occur. Even, if a pressure more than this amount is applied, Osmosis is reversed. Despite its small amount, the water molecules in the high concentration side begins passing towards the low concentration side. This incident created by force of pressure is called Reverse Osmosis. This incident is utilized in Reverse Osmosis Systems to separate the solid substances dissolved in water. The purpose of water treatment is to have the water molecules in the high concentration water (dirty water) pass to the low concentration side of the water. Osmosis occurs in the reverse way. In Reverse Osmosis, osmotic pressure is overcome by applying pressure and thus the aim is achieved.

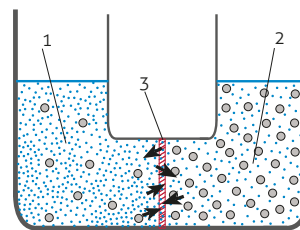

Before the osmosis

- Solvent (water)
  - Solute (solid particles)
  - Passage of water molecules through the membrane
- 1-Low concentration (high osmotic pressure and high internal energy)
  - 2-High concentration (low osmotic pressure and low internal energy)
  - 3-Membrane (semi-permeable)

# Reverse osmosis (ro) water Treatment systems

There are systematic appliances available to obtain low concentration water from high concentration water by using the reverse osmosis method.

It is possible to reverse osmosis which is a natural event. When the pressurized water is passed through the membrane wrapped as an artificial roll, most of the solid particles are retained and discharged with the waste water, the water that passes through the thin membrane is used as drinking water. Before water enters the membrane, pre-filtration processes such as sediment filter, carbon filter are carried out to retain the coarse residues and the chlorine used in the water disinfection.

Components such as these filters used before and after membrane, fittings connecting these together, pumps and switches used to increase pressure, clean water storage tank and housing etc. constitute a compact system. This system may have various configurations. Mainly, pre-filtration is composed of reverse osmosis in the membrane, pH regulation and water storage processes which are the main elements of the system.

Aura Unique Cebilon RO system consists of 3 interconnected pre-filters, membrane, pH regulator last filter, digital control group\*, pump assembly and water tank

\* Applicable for 101 ME model

\*\* Applicable for 101 ME and 101 MD models.

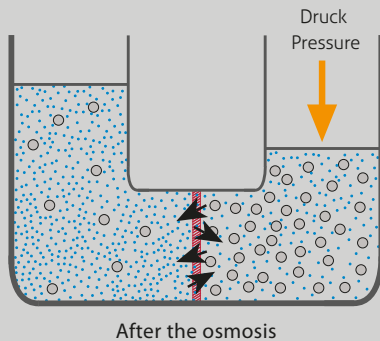

Figure 1. Osmosis and Reverse Osmosis



# Parts and functions

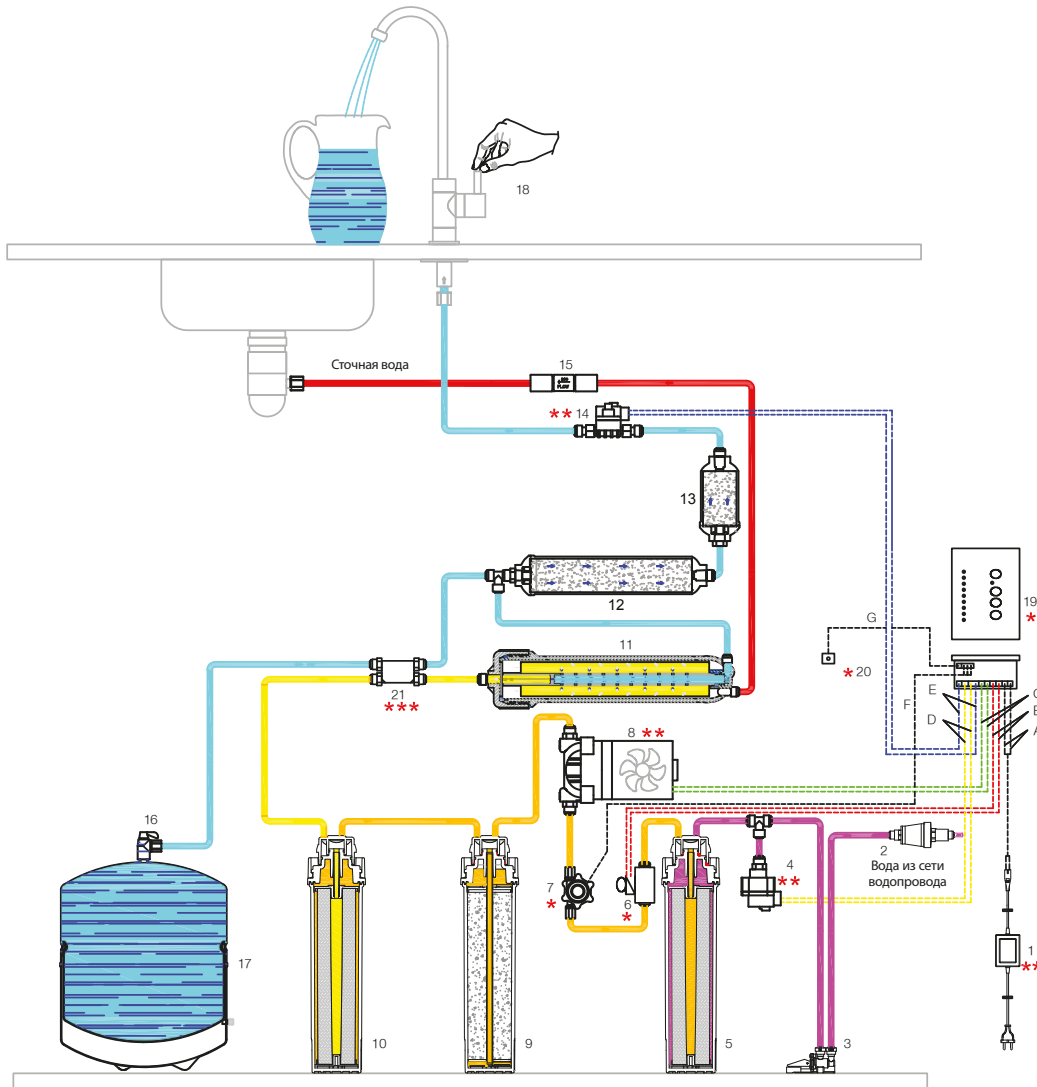

Figure 2. RO System Diagram

- Mains Water
- Water with Sediment Eliminated
- Water with Sediment and Chlorine Eliminated
- RO-Water
- Waste Water

## Cable Connection Colours

- A. White (Adapter)
- B. Red (Solenoid Valve)
- C. Green (Pump)
- D. Yellow (Low Pressure Switch)
- E. Blue (High Pressure Switch)
- F. Flowmeter
- G. Water Leakage Sensor

## Components

1. Adapter\*\*
2. Pressure regulator
3. Water leakage shut-off
4. Low pressure switch\*\*
5. 5M sediment filter
6. Solenoid valve\*
7. Flow meter\*
8. Pump (pressure pump)\*\*
9. Carbon filter
10. 1M sediment filter / carbon
11. Membrane filter
12. Last carbon filter
13. Alkaline filter (optional)
14. High pressure switch\*\*
15. Flow restrictor
16. Tank valve
17. Clean water tank
18. Clean water faucet
19. Digital display\*
20. Water leakage sensor\*
21. Automatic shut-off valve\*\*\*

\* Only available in 101 M model

\*\* Only available in 101 ME and 101 MD models.

\*\*\* Only applies to 101 MD and 101 FG models



# Functions of the parts

**Low Pressure Switch\*\***, if the water is cut or if the pressure is lower than 0.2 bar (3 psi), it prevents unnecessary operation of the pump.

**5M Sediment Filter (350003Z)**, it retains the substances and particles floating in water to make the water clear.

**Carbon Filter (350002Z)**, retains free chlorine, organic substances and unpleasant odors.

**1M Sediment Filter / Carbon Filter (350004Z)**, it retains the substances and particles floating in water to make the water clear.

**Automatic Shut-off Valve\*\*\*** controls the flow of water. If the system continues to run after the tank is full, the water is wasted as a waste. This is an undesirable condition. Water should be cut when tank capacity is reached. Automatic shut-off valve cuts the water when the tank pressure reaches a certain level of the membrane inlet pressure.

**Membrane Filter (349004Z)** is the place where the reverse osmosis occurs. A long film made of a semi-permeable material is wrapped onto a reel in two layers. These two layers are merged together with a separator between the edges of this film with two layers and it is closed to water passage. It is like a closed long narrow bag except its end wrapped on the reel with rowed holes that is on the end which allows clean water output only. This double layer film is wrapped onto a reel. Through the separator film placed between the windings, dirty water reaches all surfaces of this bag, clean water enters the bag under pressure and taken from the outlet holes. While dirty water passes by the film surfaces with a flow called cross-flow, a part of water passes through the internal part of the film as clean water (Figure 3).

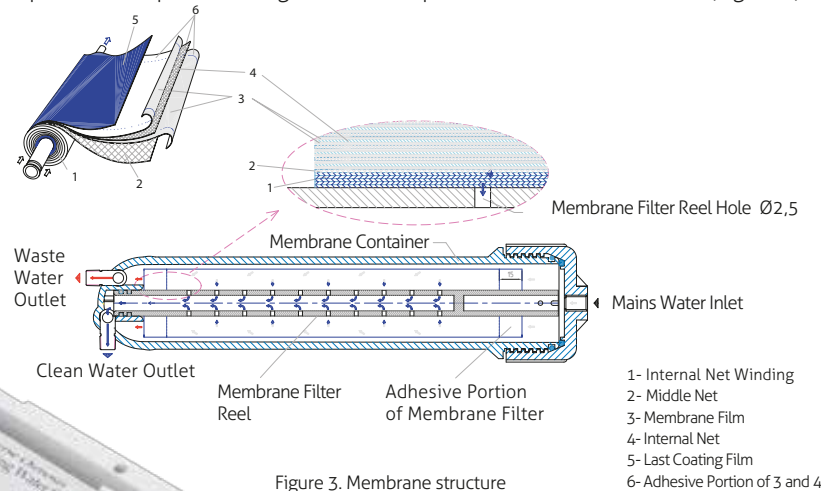

**High Pressure Switch\*\*** stops the pump when the pressure of the tank filled with clean water reaches 2.6 bar (38 psi).

**Clean Water Tank** inner surface is coated with a "food contact" plastic material suitable for food and enables clean water to be stored in a hygienic environment. Tank Valve controls the water inlet and outlet to/from the tank.

#### **Mineral Carbon Filter (340005Z06)**

provides mineral to the clean water collected in tanks or directly from the membrane before it flows from the faucet, enriches the water and regulates the pH. THROTTLE ensures formation of required pressure in the membrane by restricting flow so that the membrane can perform the separation process. It is located on the line where the waste water is drained.

**Clean Water Faucet** is where clean water is taken.

**Pump Adapter\*\*** is the power supply of the pump, it converts the mains voltage to 24 V DC.

**Solenoid Valve\*** controls the flow of water. When the water pressure in the tank reaches a certain value, it closes the water inlet and prevents water being consumed unnecessarily.

**Digital Display\*** is used for tracking the life of each filter based on the water passed through the filters. When the filter life is over, the water is cut or in case of a water leakage it alerts the user.

**Flow meter\*** is used in determining the amount of water passing through the filters and monitoring the current flow rate.

**Water Leakage Sensor\*** detects water leakage and blocks the water inlet of the system.

**Water Leakage Shut off Closes** the water inlet mechanically in case of water leakage.

\* Applicable for 101 ME model.

\*\* Applicable for 101 ME and 101 MD models.

\*\*\* Applicable for 101 MD and 101 FG models.

## *Fields of use*

This appliance is used to obtain drinking water from the mains water that have passed through the municipal treatment processes. This water should be microbiologically safe, subjected to the necessary disinfection.

If the parameters of the water are within the following ranges efficient operation of the appliance is ensured. Systems designed differently for waters such as sea water, well water, muddy water etc. with a very high TDS value are also available.

TEMPERATURE	5°C - 38°C / (38 °F - 100°F)
OPERATING PRESSURE #	40 psi-145 psi / (2,8bar-10 bar) / (275 kPa - 1.000kPa)
PH RANGE	3-11
MAXIMUM FE	0,2 (ppm=mg/L)
MAXIMUM TDS	1250 (ppm=mg/L)
TURBIDITY	5 NTU
HARDNESS	17°Fr-10°dH - 170mg/L CaCO3

# Max. pressure matches the structural integrity test value of NSF/ANSI Standard 58 for 101ME model



# Operating principle

The first filter of the system is the 5-micron sediment filter where the solid particles are retained. The water from the sediment filter is passed through the carbon filter. Granular Active Carbon (GAC) filter retains organic matter especially free chlorine and eliminates unwanted odors, carbon and other particles that may escape from the filter, is passed through the 1 micron Sediment Filter and it is ensured that the pre-membrane filter is even more suitable. This is also a factor affecting the life of the membrane. The water cleaned in three pre-filters, solid ions dissolved in the membrane that is the basis of the RO water treatment system, small particles, bacteria, viruses are retained to a large extent and given to the waste water. Among these ions are many ions such as heavy metals, sodium, lead, arsenic, nitrate, asbestos, etc. While the waste water containing the undesirable substances are discharged from one line of the membrane running with cross-flow method, water received from the other line of the cross-flow is collected in a pressurized tank. The amount of waste water should always be more than the clean water so that the membrane works in a healthy way and has a long life. Through the ready the water in the tank, water is supplied faster. Your appliance's tank capacity is 8 litres (approximately 2.2 gallons).

## Technical specifications

This appliance certified for the purification of microorganisms can also be used in waters that contain microorganisms although it has been disinfected.

Aura Cebilon Reverse Osmosis System contains critical components that are required to be replaced periodically to purify the total dissolved solid materials (TDS) efficiently. To check the efficiency of the system, water from the appliance must be periodically tested.

Your appliance contains critical components that must be replaced periodically with respect to the system's efficiency. These critical components must be replaced with components and filters with the specifications defined by the manufacturer so that the system can operate continuously with the same efficiency and performance.

aura  
cebilon  
pro

TANK CAPACITY	8 L (100 psi/689 kPa)
AIR TANK PRESSURE	6-7 psi (40-48 kPa)
DAILY CAPACITY ***	75,15 gpd (284,47 L/day)
PURIFICATION RATE ***	%85-%98
EFFICIENCY RATIO ***	30,93%
RECYCLING RATE ***	34,89%
PUMP FLOW RATE **	0,8 L/dk-1,2 L/dk
PUMP PRESSURE**	80 psi-110 psi (551-758 kPa)
POWER SUPPLY PUMP**	24 V DC
TANK SIZE	Diameter: 24.4 cm Height: 36.6 cm
DEVICE SIZE (mm)	425x490x260
BOX SIZE (mm)	580x277x450
TOTAL WEIGHT	14,5 kg(101 ME) 14 kg(101 MD) 11 kg(101 FG)

\*\* Valid for 101 ME and 101 MD models

\*\*\* Valid for 101 ME model

# Installation

Please make sure that, flushing the filters, before you start using the device. For filters flushing, you can follow the instructions below.

## Filter flushing and conditioning procedures

The first three filters shall be flushed separately. Firstly close the ball valve that supplies mains water to the system. Remove the outlet tube on the housing cover of first filter. Insert one meter  $\frac{3}{4}$  Inch tube to the outlet of the cover. And then open the ball valve, flush the filter for 2-3 minutes with mains water. Insert the outlet tube to its place and follow the same procedure for the other two filters. After that when you flush membrane filter remove tubes on the both outlets of the membrane housing. Insert one meter tube to the both outlet. Flush the membrane for 2-3 minutes to clear membrane form protective membrane solution.

Install the tube that has flow restrictor on it but not to install the tube that goes to post carbon filter. Allow water flow for

2-3 minutes to clear the membrane solution completely. And then install the tube that goes to post carbon filter. Then storage tank will be filled for the first time, tank water is let to flow for no purpose, for at least once. The appliance is now ready to use.

When you flush filters, some water drops can cause E2 (water leakage error). So dry the sensor and the device completely. Be careful that there will be no water drop in the device somewhere. If you experience such a problem, dry the sensor and device and then pull out the plug and then install the plug again the E2 error will disappear.

Also there are three pcs L elbow that is not installed to the device. These elbows should be fixed to the inlet and outlets of the device for preventing tube breakage.

Your appliance is very practical for use and the water installation can be easily installed anywhere. Installation of your appliance must be made by Authorized Services.

- Aura Cebilon Reverse Osmosis System contains critical components that are required to be replaced periodically to purify the total dissolved solid materials (TDS). To check the efficiency of the system, water from the appliance must be periodically tested.

- Free chlorine may affect the polymer structure of the membrane filter that is located inside the system.

- Please read the instruction manual for installation, operation, maintenance and warranty terms. Installation diagram for the appliance is shown in Figure 4.

## WARNING

- 1- Measures should be taken against freezing.
- 2- Waste water should not interfered with.
- 3- When muddy (clay) water comes from the mains, close the water inlet of the appliance.
- 4- If a water supply other than the mains will be used, you must receive a drinking water report from relevant institutions.
- 5- If it is a water source other than the mains water, make sure that the disinfection process is performed.
- 6- Filters are considered as supplies and are outside the scope of warranty.

# Installation scheme

- Mains Water
- RO-Water
- Waste Water

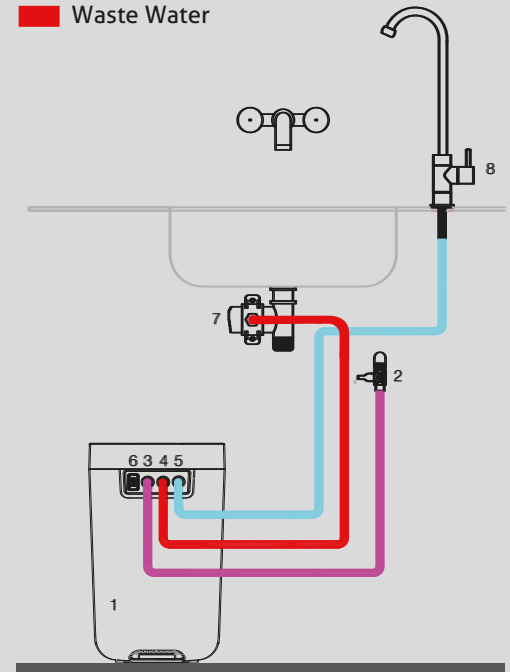

- 1- Cebilon
- 2- Water Inlet Valve
- 3- Appliance Water Inlet
- 4- Waste Water Outlet
- 5- RO Water Outlet (Clean Water)
- 6- 24 V Input \*\*
- 7- Waste Water Bracket
- 8- Clean Water Faucet

\*\*Applicable for 101 ME and 101 MD models.

Figure 4. RO Installation Diagram

## Water connection

- Close the mains water from the apartment inlet valve.
- After draining the water left in the pipes from proper places, mount the three-way adapter to the mains by ensuring the sealing.
- First, mount the 1/4 ball valve to the three-way adapter by wrapping a teflon tape in a position so that the valve is opened and closed easily (Figure 5.a).
- Connect the water inlet hose to the ball valve (Figure 5.b).
- Make sure the ball valve is closed (Figure 5.c).
- Open the mains water, check whether there is any leakage (Figure 5.d).
- Place the appliance on a suitable place underneath the counter in upright position.

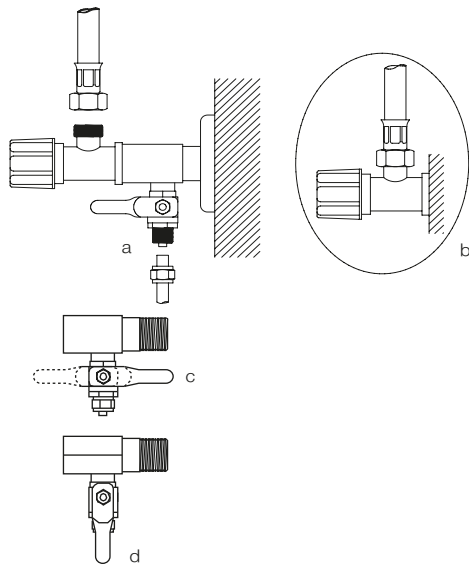

Figure 5. Water connection fittings

## Installing the faucet

Clean water faucet should be mounted carefully in terms of use and aesthetics. If the counter or kitchen sink will be drilled, drilling process should be proceeded after the dimensions are obtained so as to install the washers, nuts and unions under the counter or kitchen sink (Figure 6). Otherwise, drilling may be incorrect.

The location to be drilled may be granite, marble, concrete or stainless sink. If the counter is granite, it must be drilled with a 20 mm diameter bore bit. Bore bit is attached to the end of the drill and it is set to low speed. Water is poured on the ground to be drilled (do not drill without water). Bend the bore bit as 45 degrees and press slightly, it makes a trail on the granite. Then it is brought to an upright position slowly without lifting. When it reaches the upright position, drilling is completed by applying enough force. If the bore bit is not kept constant when we start drilling, parts can break off from the granite surface. The o-ring on the faucet's mirror cannot ensure sealing and may cause the water leakage down from the counter. Marble countertops can be drilled by the same drilling bit or bore bit. Concrete countertops are drilled with a contact tip and hammer drill. If concrete is coated with tiles, a pre drill is made with a small-diameter drill bit to avoid cracking the tiles. Bore bit for the stainless sinks is different.

The hose should be mounted carefully between the faucet mounted on the counter and on the appliance where "Clean Water" is written.

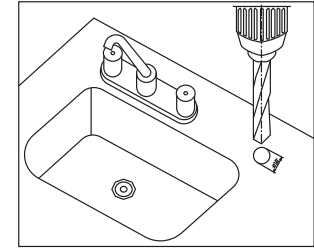

- 1- Faucet Pipe
- 2- Upper Body Part
- 3- Opening/Closing Handle
- 4- Hub Cover
- 5- Faucet Body
- 6- Body Bushing
- 7- Body Bushing O-ring
- 8- Mounting Parts
- 9- Mounting Plastic
- 10- Plastic Mounting Washer
- 11- Crinkled Spring Washer
- 12- Compression Nut
- 13- Faucet Screw
- 14- 1/4" Hose

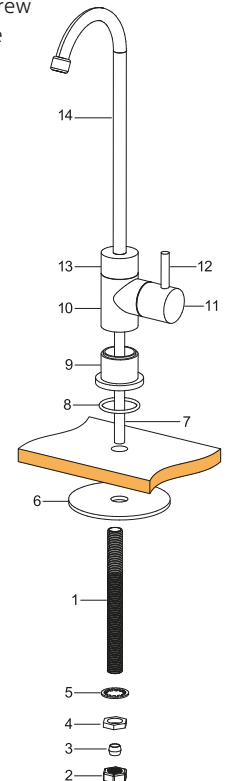

Figure 6. Faucet

## Waste Water Connection

- If waste water pipe of the sink is not a throat hose but a 40 mm plastic pipe, it is mounted in a 3/8" clamp sealing sponge affixed state (Figure 7a).
- The flush is drilled from the hole of the clamp in 8 mm diameter on the same axis (Figure 7b). One end of the 3/8" waste water faucet is connected to this clamp and the other end is connected to the 3/8" waste water union.
- If waste water hose will be mounted on the 50 waste water installation, a 3/8" clamp will be mounted and the waste water hose will be mounted on its location above this. A seal must be used when mounting the adapter to the waste water installation.

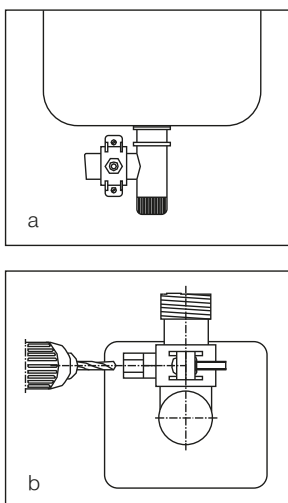

Figure 7. Waste water connection

## Pre-tests

- The adapter is plugged in after it is placed into the place where "24 V DC" is written on the appliance. In this case, it will not work due to lack of water and pressure in the system.\*\*
- Clean water faucet is turned on
- Tank valve must be closed.
- Mains water is supplied to the system by opening the 1/4 ball valve (Figure 8). It is seen that the pump is running.\*\*
- The faucet is closed after a small amount of water flows from the clean water faucet.\*\*
- After the operation of the pump stops, leak test of all the connections in the system is performed, the tank valve opens.
- This system should be used after the twenty-four hours washing process, (Installation is done after this process is carried out by an authorized service.)
- After the washing process since the tank will be filled with water for the first time. Tank water is let to flow for no purpose. Now the appliance is ready to use.

\*\* Included in the 101 ME and 101 MD models only.

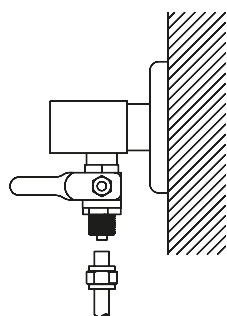

Figure 8. Mains inlet valve

## Points for Attention

- The appliance is designed for domestic use. Parts such as storage tank, waste water hose, faucet must be attached indoor environment. Necessary measures should be taken to prevent freezing and waste water flow.
- Use the appliance after the necessary measures are taken in microbiologically unsafe or disinfected waters.
- The appliance must be supplied with its own power adapter.
- If the appliance will not be used for a long time (such as more than 1 month), the inlet water valve must be closed (figure 9), the tank should be drained and the adapter should be plugged out and the authorizes service must be called to disinfect the appliance when reactivating.
- When there not anyone in the house, close the water inlet valve of the appliance for safety purposes (Figure 8).
- The appliance must not be interfered for repair and maintenance purposes. Otherwise, it falls out of the warranty scope, these operations are carried out by authorized service.
- As the inlet water temperature changes, the amount of clean water to be received and the efficiency may change. Therefore, water obtained may be low in winter and high in summer.
- In any unfavorableness (Figure 8) close the water inlet valve and consult authorized service.





# Maintenance

Maintenance of your appliance must be performed by an authorized service, appliances that of the maintenance is not performed by an authorized service will fall out of warranty.

The life of the filters used in Aura Cebilon Reverse Osmosis System changes depending on various factors with the amount of water used. These major factors are inlet water quality, chlorine amount, residue amount etc. Filters are considered as supplies and they are out of warranty.

# Filter Replacement

- Pull the front cover towards yourself. (Figure 9a)
- The filter to be replaced is lifted up 30 degrees. (Figure 9b). Then, it is turned to left 90 degrees and removed (Figure 9c).
- The new filter is fitted by turning 90 degrees to the right (Figure 9d). Then, it is lowered down 30 degrees to its former location. (Figure 9e)
- The front cover is fitted back.

## WARNING

The ball valve and the tank valve in the appliance are closed respectively before the filter replacement. The pressure in the system is removed by opening the faucet of the appliance. Filter replacement is carried out after the E0 error appears on the screen and after the alarm sounds. (for 101 ME model)

After the filter replacement process is finished, the ball valve is opened respectively. When water starts to come from the faucet, tank valve opens and the faucet is closed. Filter must not be replaced when inlet water is open and without removing the pressure in the appliance.



# Performance Data Sheet

101ME model system conform to NSF/ANSI 58 for the specific performance claims as verified and substantiated by test data.

- Do not use this system with any water that is microbiologically unsafe, that does not have adequate disinfection before or after operation or that of the quality is unknown.
- Aura Cebilon Reverse Osmosis System contains critical components that are required to be replaced periodically to purify the total dissolved solid materials (TDS). To check the efficiency of the system, water from the appliance must be tested periodically.
- Your appliance contains critical components that must be replaced periodically with respect to the system's efficiency. These critical components must be replaced with components and filters with the specifications defined by the manufacturer so that the system can operate continuously with the same efficiency and performance.

101ME has been tested according to NSF/ANSI 58 for reduction of substances listed below. The concentration of the indicated substances in water entering the system was reduced to a concentration less than or equal to the permissible limit for water leaving the system, as specified in NSF/ANSI 58. Testing was performed under standard laboratory conditions, actual performance vary.

Substance	Influent Challenge Concentration	Average Influent (mg/L)	Average Effluent (mg/L)
Total dissolved solids (TDS)	750 ± 40	770	30

Substance	Average % Reduction	Maximum permissible product water concentration (mg/L)
Total dissolved solids (TDS)	96.0%	187



### Daily capacity, efficiency rating and recovery rating for IO1ME model

\* Efficiency rating means the percentage of the influent water to the system that is available to the user as reverse osmosis treated water under operating conditions that approximate typical daily usage.

\*\* Recovery rating means the percentage of the influent water to the membrane portion of the system that is available to the user as reverse osmosis treated water when the system is operated without a storage tank or when the storage tank is bypassed

Daily Capacity	75.15 gpd (284.47 L/day)
Efficiency Rate(*)	30.93%
Recycling Rate (**)	34.89%
Operating Pressure (min-max) #	40-145psi / 2.8-10 bar / 275-1.000 kPa
Operating Temperature (min-max)	5-38°C/38-100°F
Ph Range	3-11
Maximum Fe (Iron)	0,2 (ppm=mg/L)
Maximum TDS	1250 (ppm=mg/L)
Turbidity	5 NTU
Hardness	17 °Fr-10 °dH -170 mg/LCaCO3

# Max. pressure matches the structural integrity test value of NSF/ANSI Standard 58 for IO1ME model

## Recommended filter replacement periods

Have timely periodic maintenance of your appliance to use your system efficiently and for longer time. The following replacement periods are the recommended durations for appliances used in mains water under normal conditions. The usage condition of your appliance may change depending on the properties of inlet water, amount of chlorine and sediment. Our authorized services will perform periodic maintenance required for your system to work efficiently every six months.

Filter Name	Part Code	Replacement Period	Duties
5 micron sediment filter	350010Z	6 months or 1500 galons	Sediment filtration is performed by taking coarse particles in water. Clears the water at a micron level. Its life varies depending on the nature of the inlet water.
Carbon filter	350002Z	6-12 months or 3000 galons	Keeps all the gas in water chemically in itself. The excess chlorine reduces the life of the carbon filter. Timely replacement protects from damage of chlorine and extends the life of the membrane filter.
1 micron sediment filter / carbon filter	350003Z	6-12 months or 3000 galons	This filtration is performed by taking coarse particles in water. Clears the water at a micron level. Its life varies depending on the nature of the inlet water.
Mineral carbon filter	340005Z	6-12 months or 3000 galons	Regulates the pH by supplying mineral to water.
Membrane	349004Z	2 – 5 years 6000 galons	This is where Reverse Osmosis occurs. Life of the filter will change depending on the ion concentration in the mains water, amount of the distilled water and whether the maintenance is carried out in a timely manner.



## Information about Arsenic

Arsenic is generally found in two forms in well water or groundwater: Arsenic V (inorganic), +5 valence arsenic, (also known as As(V)\As+5 or arsenic) and Arsenic III (organic), +3 valence arsenic (also called As (III) \ (As + 3) or arsenic). Arsenic dissolved in water leaves no color, no taste, no smell. Arsenic content can only be measured in laboratory conditions using special tests. All drinking water supplied by state enterprises and institutions must be tested for arsenic content without fail. The results of these tests can be obtained from the local water supply organizations. If you consume water from your own well, you are also advised to have it tested. To do this, you can obtain a list of accredited laboratories certified in this area from local health and environmental authorities. You can also get information about the content of arsenic in water from the official website of local state water supply companies or the U.S. Environmental Protection Agency ([www.epa.gov](http://www.epa.gov)).

In water, arsenic is usually present in the form of (As+5), (As+3) or a combination of both forms. It is possible to determine exactly what form of arsenic and what concentration of arsenic is contained in water in the laboratory by conducting special tests on water samples taken using special sampling procedures. To obtain this service, you might contact the laboratories located at your place of residence.

Reverse osmosis (RO) water purification systems do not have a good ability to retain trivalent arsenic. They are highly effective in purifying water from pentavalent arsenic. Free chlorine molecules quickly convert +3 valence arsenic (As+3) into +5 valence arsenic (As+5). At the same time, other cleaning chemicals such as ozone and potassium permanganate are also able to convert +3 valence arsenic to +5 valence. But chlorine compounds (chloramine) do not do so well with the task of converting +3 valence arsenic. If you are using city water, it would be wise to ask the providing establishment if they have used free chlorine molecules or chloramine in their water treatment.

The Aura Cebilon reverse osmosis system is designed specifically to purify water from +5 valence arsenic (As+5). This system is not designed to convert +3 valence arsenic (As+3) to +5 valence arsenic (As+5). In laboratory testing of the system, +5 valence arsenic (As+5), at a concentration of 0.30 mg/L (ppm), was reduced to levels below the EPA Standards and Regulations for Arsenic in Drinking Water US environments, below 0.010 mg/l (ppm) (0.004 mg/l). The result obtained from the laboratory may vary depending on the places of use, usage conditions and the characteristics of the inlet water. To monitor the system's ability to retain arsenic, regularly monitor the operation of all system components.



# Aura Cebilon Reverse Osmosis System

## Part List

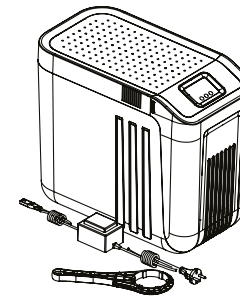
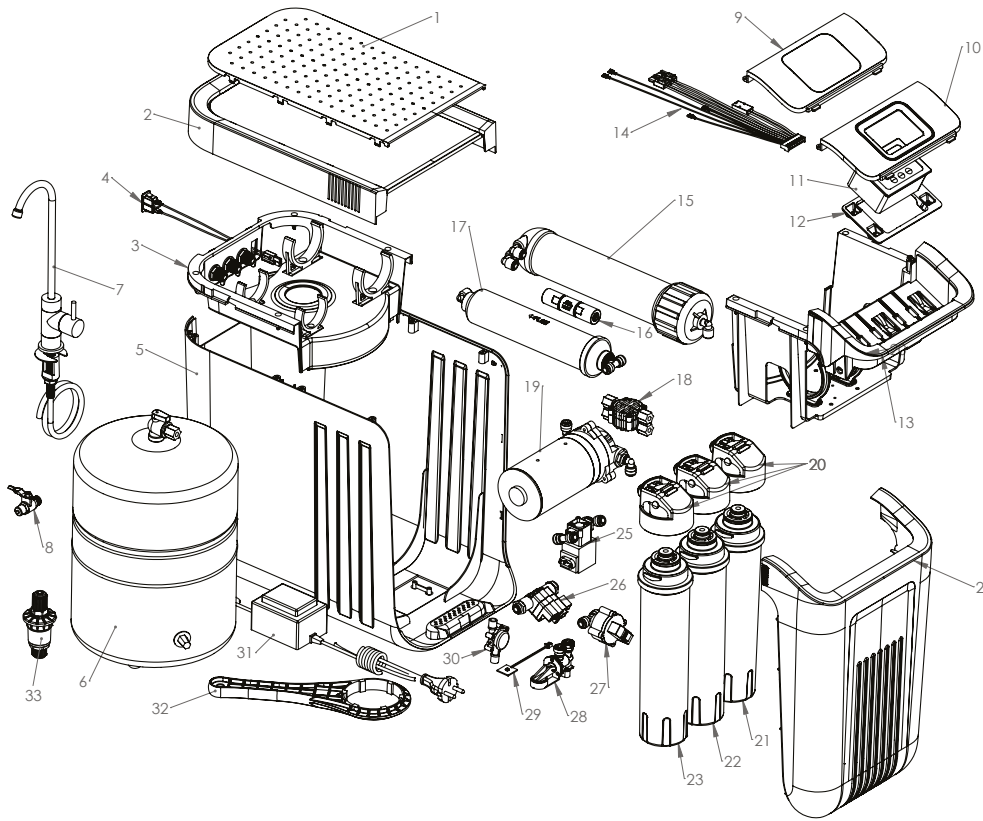

P. No	Part Code	PartName	P. No	Part Code	PartName
1	351004Z	Top Cover Panel	18	340006Z	Auto Shutoff Valve***
2	351003Z	Top Cover	19	346003Z03	Pressure Pump**
3	351021Z	Upper Body Back	20	350008Z	Filter Housing Cover Group
4	356006Z	Cable Group (Plug Type) 680 mm**	21	350003Z	5M Sediment Filter Group
5	351001Z	Bottom Body	22	350002Z	Carbon Filter Group
6	350001Z	Clean Water Tank (8 Litre)	23	350004Z	1M Sediment / Carbon Filter Group
7	343034Z	Clean water faucet (Air gap)	24	351011Z	Front Cover
8	343002Z	Ball Valve 1/4	25	356004Z	Solenoid Valve*
9	351022Z	Upper Body Panel ***	26	346002Z	High Pressure Switch **
10	351005Z	Digital Display Cover*	27	346001Z	Low Pressure Switch **
11	356001Z	Digital Display*	28	340059Z01	Water Leakage Shutoff Apparatus
12	351006Z	Digital Display Fixing Plastic*	29	356005Z	Water Leakage Sensor*
13	351002Z	Upper Body Front	30	356003Z	Flow Meter*
14	356002Z	Digital Display Cable Group*	31	356007Z	Adapter 24 V (L Type Plug)**
15	341143Z	Membrane Housing	32	351020Z	Membrane Housing Wrench
16	341106Z	Flow Restrictor	33	351020Z	Pressure Regulator
17	340005Z	Mineral Last Carbon Filter			

\* Only available in 101 ME model.

\*\* Only applies to 101 ME and 101 MD models.

\*\*\* Only applies to 101 MD and 101 FG models.

# Troubleshooting



PROBLEM	POSSIBLE CAUSES	RECOMMENDED SOLUTION
Foam in water or milky coloured water.	Air in the system.	Air in the system is a normal occurrence after initial installation. Sometimes, air caused by the mains may exist. This will return to normal after usage for a while. There is no inconvenience for using this water.
Low water from the appliance.	Pump is not operating and there is no sufficient pressure.**	Check whether the pump adaptor is plugged in. If adaptor is plugged in, consult to your service.**
	There is bending, crushing on the hoses.	Check all the hoses connected to the appliance, eliminate bendings, if any.
	Pre-filter group is clogged.	Please consult the service.
	Membrane does not perform well.	Please consult the service.
	Inlet water temperature dropped.	This is not a fault. Decrease in clean water is normal during winter.
Check valve is defective.	Please consult the service.	
No water is received from the faucet despite the tank is full.	Tank storage air pressure is insufficient.	Insufficient air in the tank. Please consult the service.
There is noise in the appliance.	Regulator	If regulator setting pressure is equal to the mains water, this may make noise. The noise will stop when mains pressure is back to normal.
	Waste water hose may make noise.	Make the position of the clamp attached to the flush and the waste water hose passing through it proper.
	This may occur due to clogging and bending of the waste water hose.	Clean the clogging of the drain hose or straighten the bended hose.
The pump is running continuously.**	High Pressure Switch may be defective.**	Close the inlet water and consult to your service.
	Low Pressure Switch may be defective.**	Close the inlet water and consult to your service.
	Check valve may be defective.	Please consult the service.
	Shut off valve may be defective.	
Pump may be defective.		
EO is shown on the display and the appliance does not provide water. (Figure 10a)	There is no mains water.	Close the ball valve since there is no clean water supplied to the mains after water is cut. When the water returns, open the ball valve after the mains water starts to flow clean. Your appliance will be ready to use.
E1 will be shown on the display (Figure 10b).	Filter life is completed.	Please consult the service.
E2 will be shown on the display (Figure 10c).	Water leakage is detected.	Please consult the service. Close the ball valve and cut the water inlet.
 icon is shown on the display (Figure 10d).	It indicates that the filter life is nearly completed.	Please consult the service.

\* This table only applies to 101ME model.

\*\* Only applies to 101 ME and 101 MD models.

# Digital display functions

You can switch between modes on the digital screen by pressing the menu button. There are 7 modes available on the digital screen. These are;

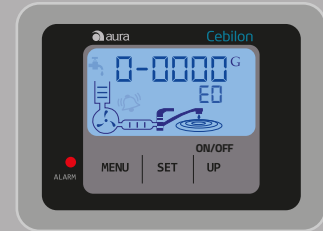

(Figure 10 a)

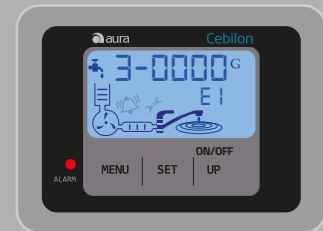

(Figure 10 b)

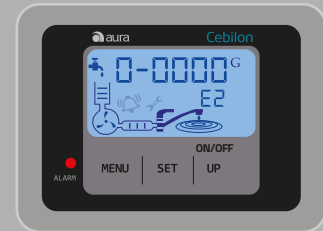

(Figure 10 c)

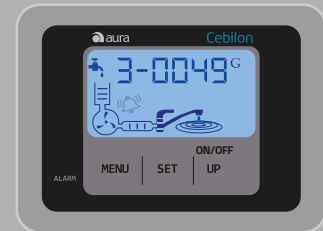

(Figure 10 d)

## Digital display functions

You can switch between modes on the digital screen by pressing the menu button. There are 7 modes available on the digital screen.

These are;

**F MODE:** Shows the instant water flow in litre/min. (Figure 11 a).

**0 MODE:** Shows the total water amount passing through the appliance in gallon. As water passes through the appliance, the value increases (Figure 11 b).

**1 MODE:** Shows the life of the 5 micron sediment filter in gallon. As water passes through the appliance, the value decreases. (Figure 11 c),

**2 MODE:** Shows the life of GAC filter in gallon. As water passes through the appliance, the value decreases. (Figure 11d),

**3 MODE:** Shows the life of the 1 micron sediment filter in gallon. As water passes through the appliance, the value decreases. (Figure 11e).

**4 MODE:** Shows the life of RO membrane filter in gallon. As water passes through the appliance, the value decreases. (Figure 11f).

**5 MODE:** Shows the life of the last mineral carbon filter in gallon. As water passes through the appliance, the value decreases. (Figure 11g).

**Values in Figure 11 are sample values.**

**\*Only available in 101 ME model.**

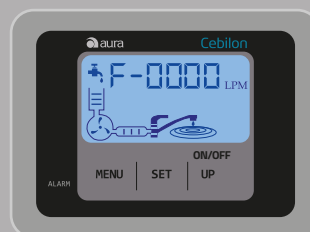

(Figure 11 a)

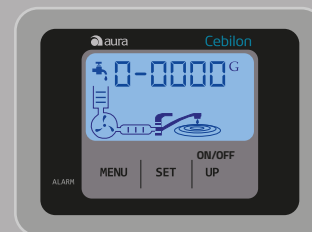

(Figure 11 b)

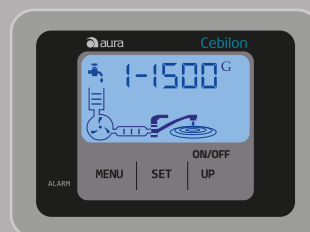

(Figure 11 c)

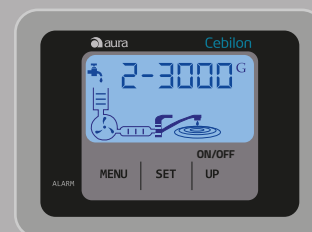

(Figure 11 d)

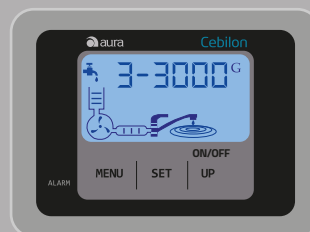

(Figure 11 e)

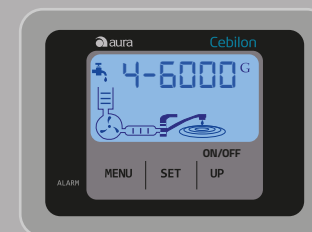

(Figure 11 f)

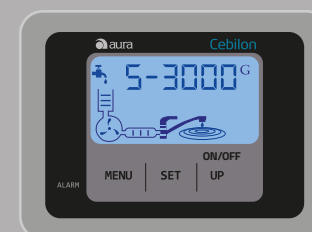

(Figure 11 g)

# Maintenance card



Customers Name Surname : _____			Installation Date : _____					SERVICE TELEPHONE _____		PRODUCT SERIAL NO. _____	
Address : _____			Number of People in the Family : _____								
Tel: _____			Mains Water TUS Value : _____								
Order No.	Filter Replacement Date PRODUCT SERIAL NO.	Recommended Next Filter Replacement Date	REPLACED FILTERS					TDS Before Filter Replacement	TDS After Filter Replacement	Service Personnel Name Surname _____	Signature
			Sediment Filter	Carbon Filter	3rd Filter	Membran Filter	Mineral Carbon Filter				
First Installation			-	-	-	-	-	-			
1											
2											
3											
4											
5											
6											
7											
8											
9											
10											
11											
12											
13											
14											
15											
16											
17											
18											
19											
20											

PLEASE WARN US FOR TIMELY MAINTENANCE. DO NOT LOSE YOUR CARD



Customers Name Surname : _____			Installation Date : _____					SERVICE TELEPHONE _____		PRODUCT SERIAL NO. _____	
Address : _____			Number of People in the Family : _____								
Tel: _____			Mains Water TUS Value : _____								
Order No.	Filter Replacement Date PRODUCT SERIAL NO.	Recommended Next Filter Replacement Date	REPLACED FILTERS					TDS Before Filter Replacement	TDS After Filter Replacement	Service Personnel Name Surname _____	Signature
			Sediment Filter	Carbon Filter	3th Filter	Membran Filter	Mineral Carbon Filter				
First Installation			-	-	-	-	-	-			
1											
2											
3											
4											
5											
6											
7											
8											
9											
10											
11											
12											
13											
14											
15											
16											
17											
18											
19											
20											

# Installation control card

## O. No Points to Be Checked

	<b>Yes</b>	<b>No</b>
1 Have you measured the amount of chlorine in the mains water?	<input type="checkbox"/>	<input type="checkbox"/>
2 Have you measured the hardness of water?	<input type="checkbox"/>	<input type="checkbox"/>
3 Have you measured the TDS level of water?	<input type="checkbox"/>	<input type="checkbox"/>
4 Have you measured the pressure of water?	<input type="checkbox"/>	<input type="checkbox"/>
5 Is the tank pressure suitable?	<input type="checkbox"/>	<input type="checkbox"/>
6 Have you counselled with the customer for the proper location of the appliance?	<input type="checkbox"/>	<input type="checkbox"/>
7 Has the sealing been ensured for three-way adapter installation in full?	<input type="checkbox"/>	<input type="checkbox"/>
8 Have you counselled with the customer for the faucet mounting hole?	<input type="checkbox"/>	<input type="checkbox"/>
9 Is the driller suitable for the counter material?	<input type="checkbox"/>	<input type="checkbox"/>
10 Is there any suitable plugs for the adapter of the appliance?***	<input type="checkbox"/>	<input type="checkbox"/>
11 Have you checked the chlorine in the membrane inlet after installation?	<input type="checkbox"/>	<input type="checkbox"/>
12 Have you checked clean water/waste water ratio?	<input type="checkbox"/>	<input type="checkbox"/>
13 Have you selected the throttle based on the mains water hardness and have you used siliphos?	<input type="checkbox"/>	<input type="checkbox"/>
14 Have you performed solenoid valve checks?*	<input type="checkbox"/>	<input type="checkbox"/>
15 Have you performed automatic closing valve checks? ***	<input type="checkbox"/>	<input type="checkbox"/>
16 Has the Low Pressure Switch run the pump? **	<input type="checkbox"/>	<input type="checkbox"/>
17 Has the Low Pressure Switch stopped the pump? **	<input type="checkbox"/>	<input type="checkbox"/>
18 Has the High Pressure Switch stopped the pump? **	<input type="checkbox"/>	<input type="checkbox"/>
19 Have you performed leakage checks?	<input type="checkbox"/>	<input type="checkbox"/>
20 Have you operated the pump of the appliance while performing these processes? **	<input type="checkbox"/>	<input type="checkbox"/>
21 Is the connection of waste water hose to the drainage proper?	<input type="checkbox"/>	<input type="checkbox"/>
22 Is the customer informed that they should drain one tank of water?	<input type="checkbox"/>	<input type="checkbox"/>
23 Has the maintenance card filled?	<input type="checkbox"/>	<input type="checkbox"/>
24 Are the required explanations made to the customer?	<input type="checkbox"/>	<input type="checkbox"/>

\* Only applies to 101ME.

\*\* Only applies to 101 ME and 101 MD models.

\*\*\* Only applies to 101 MD and 101 FG models.

Personnel Performing the Installation .....

Date : .....

Appliance Serial No : .....

### ***Seller Company Information***

Company Name: .....

Address : .....

Tel : .....

Sales Date : .....



#### ***Complies with WEEE Regulation***

This symbol on the product or packaging shows that the product should not be disposed of with normal domestic waste and should be transmitted to the collection points for recycling the electrical and electronic appliances. If you dispose of this product correctly, you will be contributing to the protection of the nature and human health. Wrong disposal will be harmful to the nature and human health. You may find further information on recycling this product from your municipal, waste collection service or from the store you have purchased the appliance.

***FOR INFORMATION AND SUPPORT SERVICES***

Country :

Name of the Distributor Company :

Telephone and Fax. :